



GUIDE DE MONTAGE

Habillage et détaillage du châssis

IXOBOX N°2

Les pièces du kit numéro 5

- 5A** Châssis
- 5B** Support du frein du 4^e essieu moteur gauche (L)
- 5C** Support du frein du 4^e essieu moteur droite (R)
- 5D** Renfort de traverse arrière
- AM** M1,7 x 4 (4 + 1)

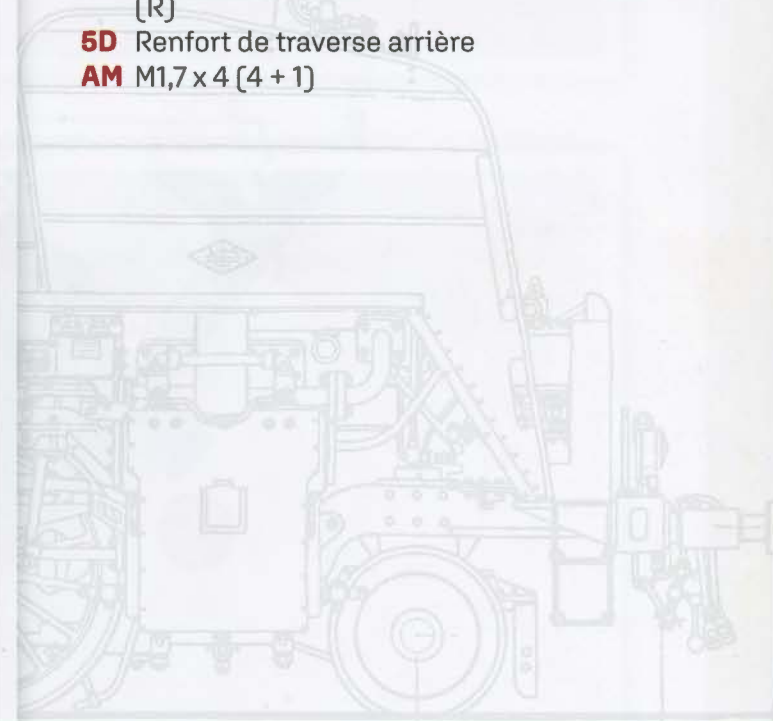
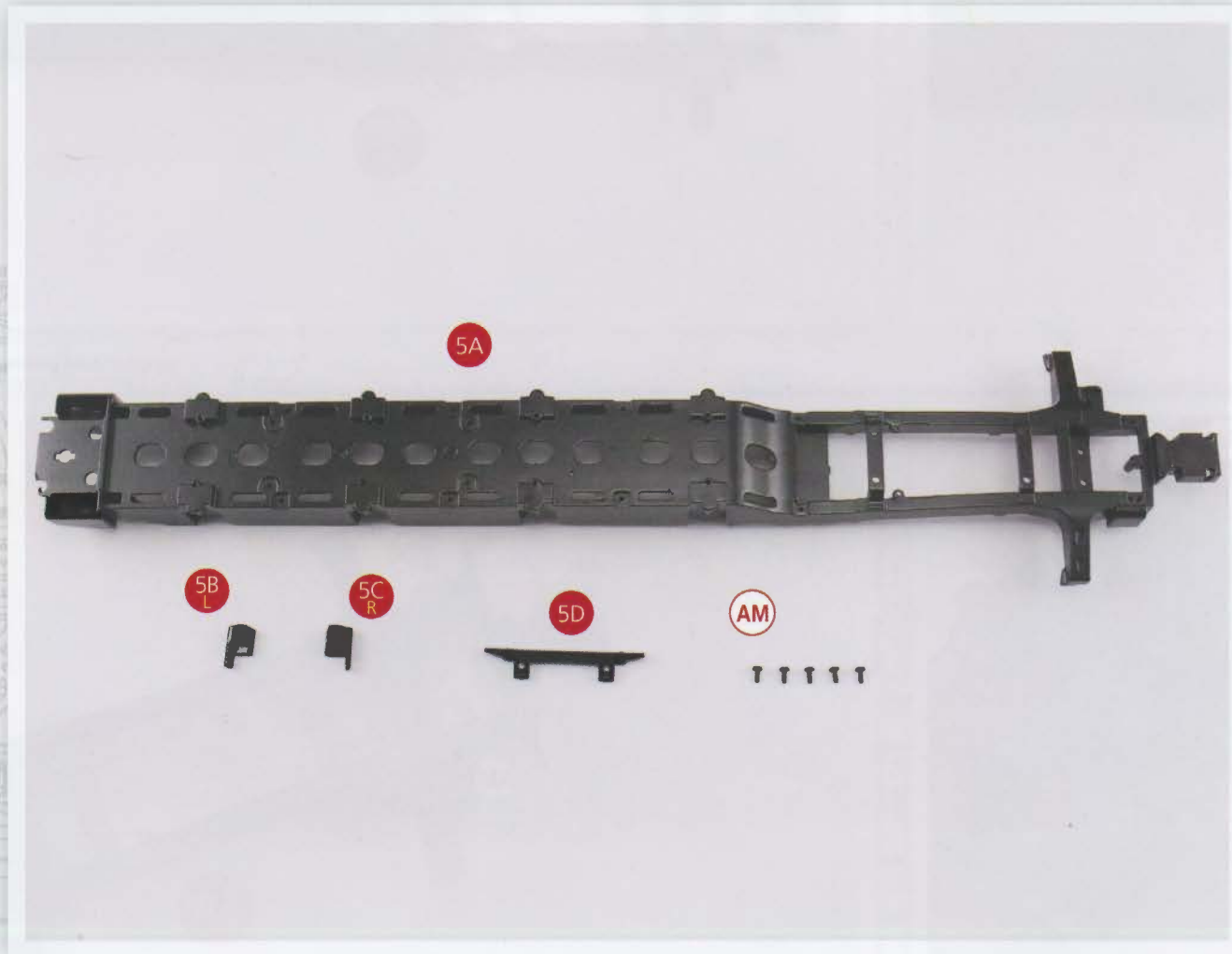

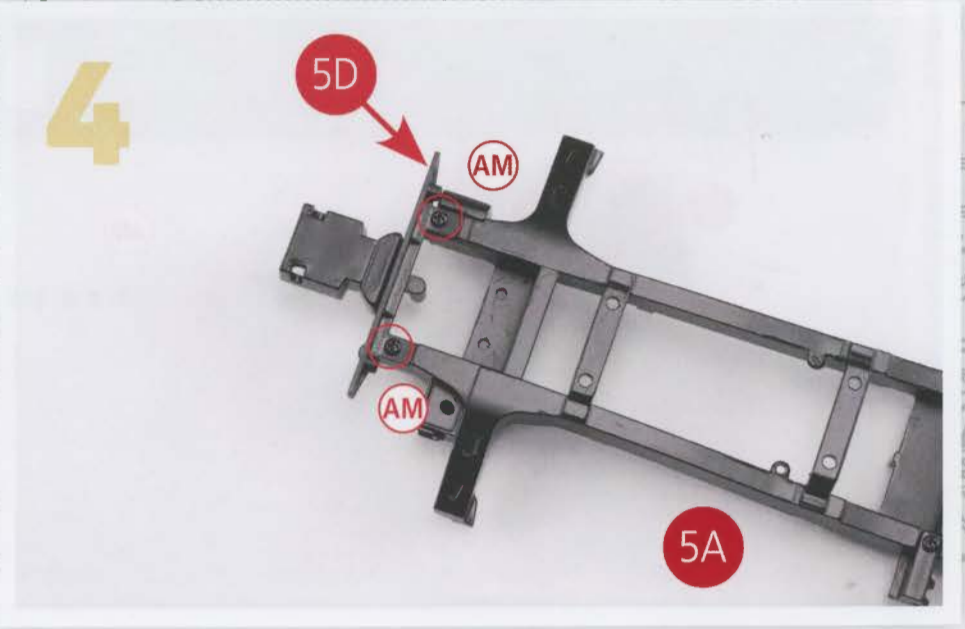
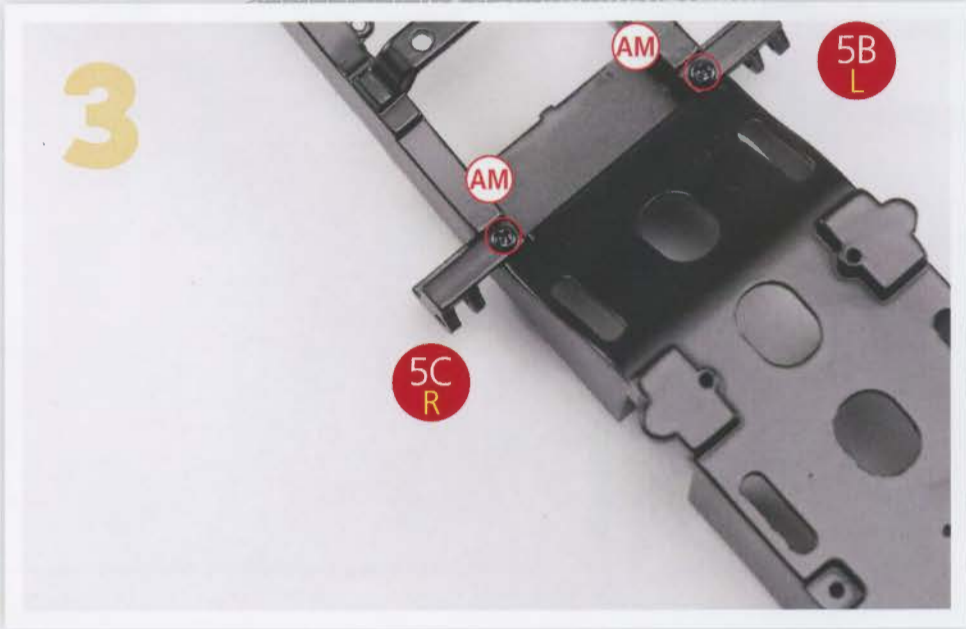
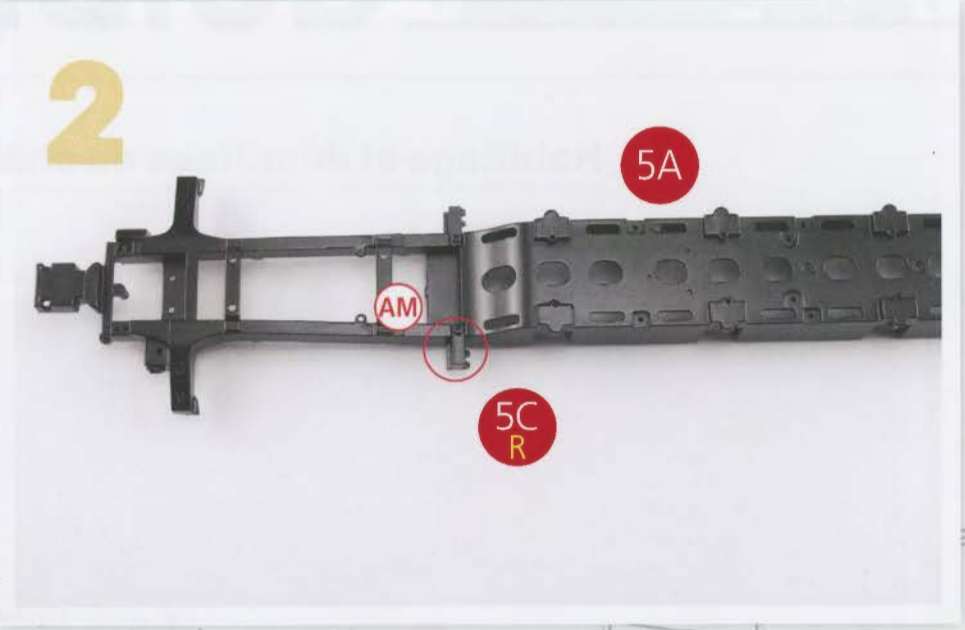
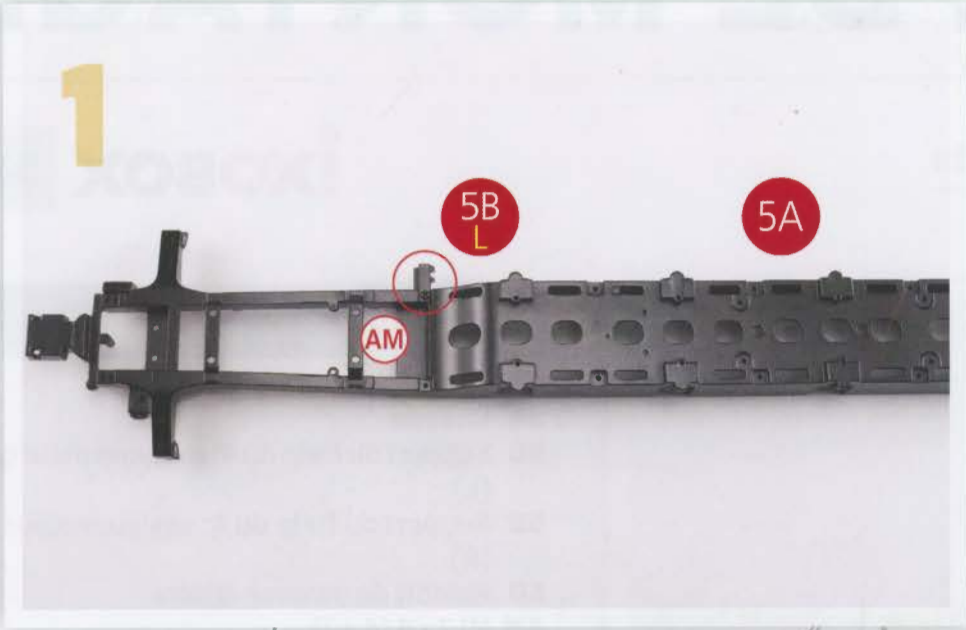

VUE FINALE





GUIDE DE MONTAGE

Montage des tirants des ressorts à lames de la suspension

IXOBOX N°2

Les pièces du kit numéro 6

- 6A** Supports (x6) des freins gauche
- 6B** Suspensions des autres essieux moteurs
- 6C** Tirants supplémentaires des suspensions
- 6D** Cache-vis des roues du bissel avant (x2)
- AM** M1,7 x 4 (14 + 2)

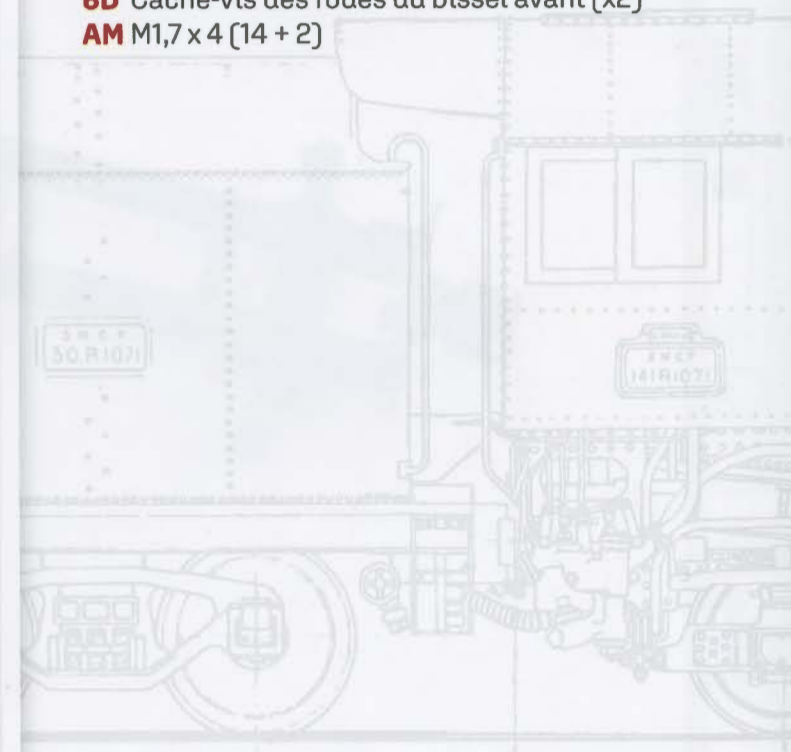
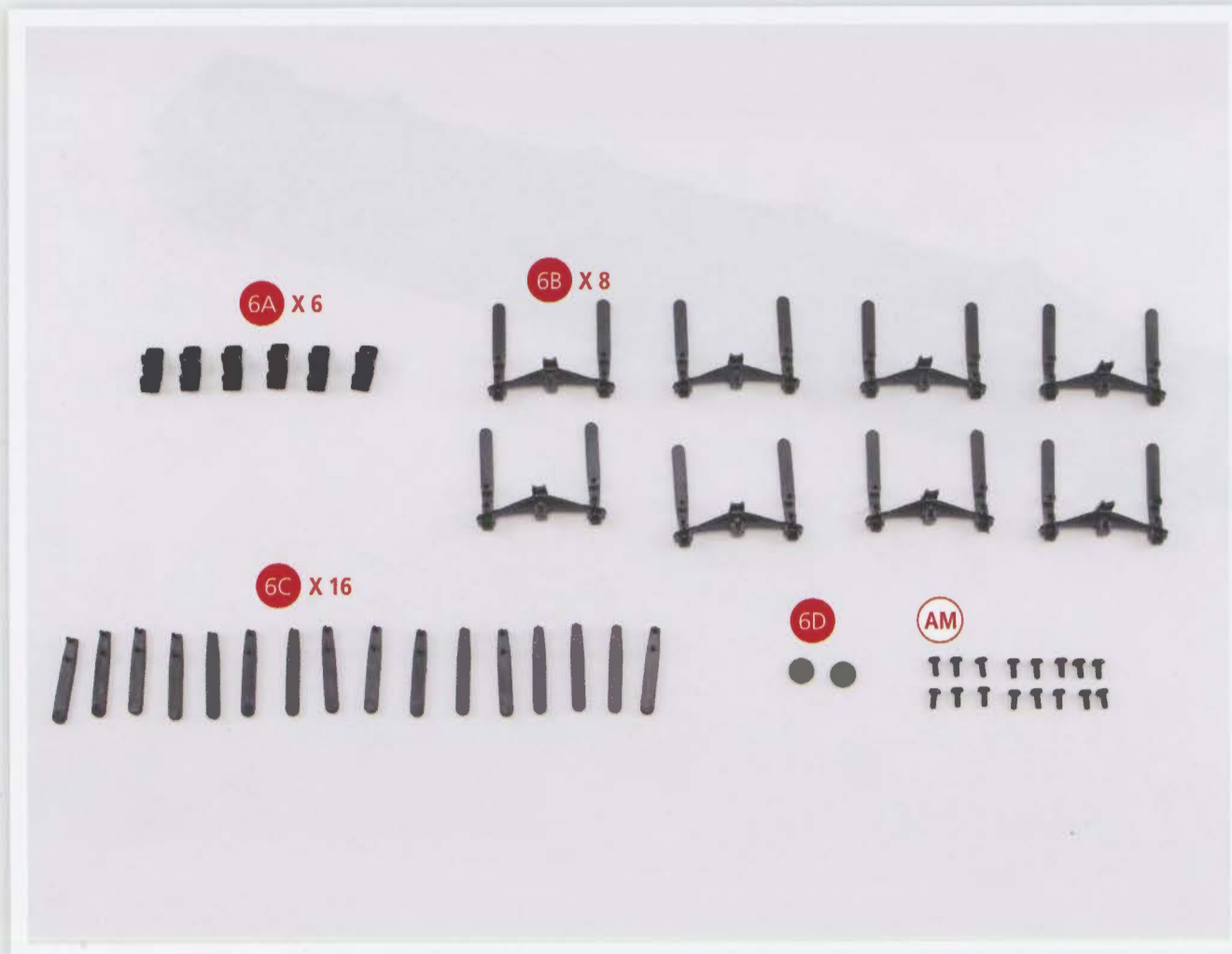

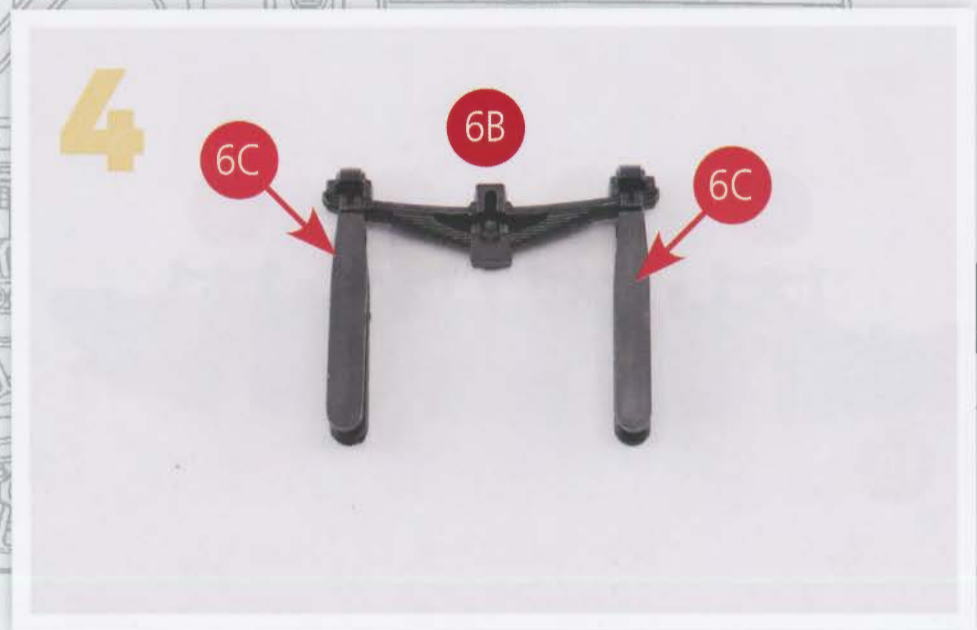
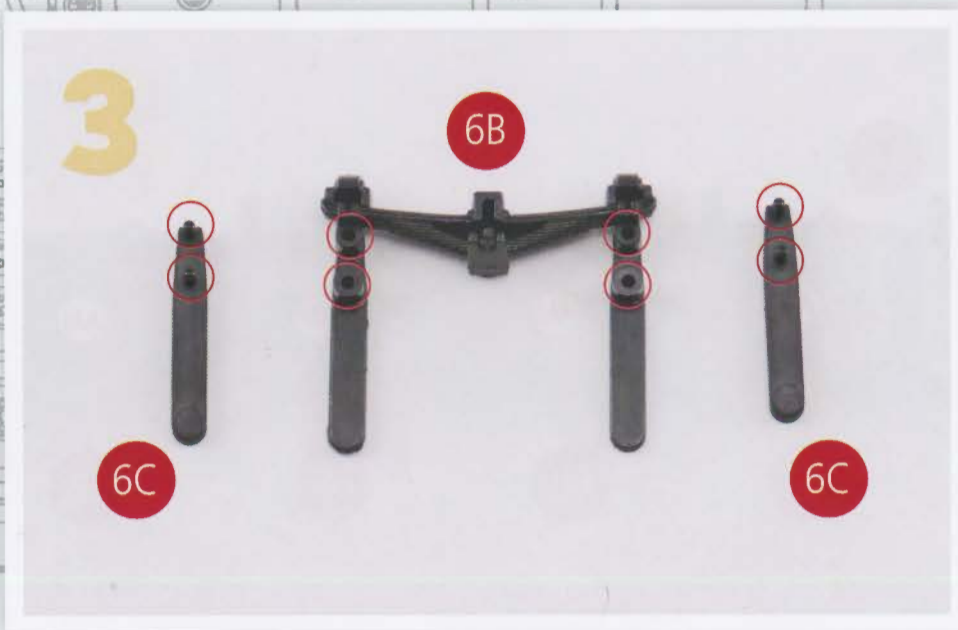
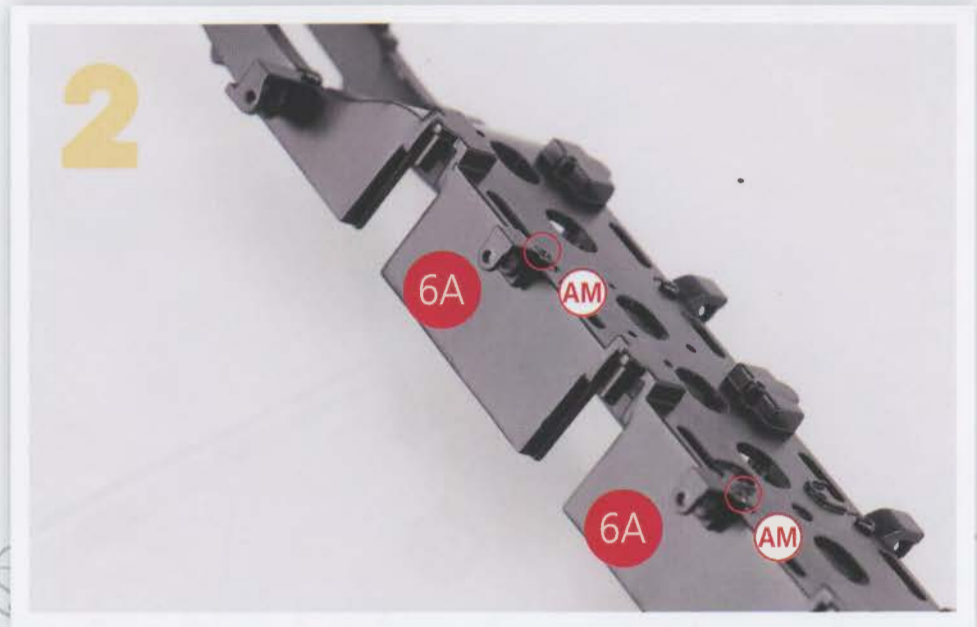
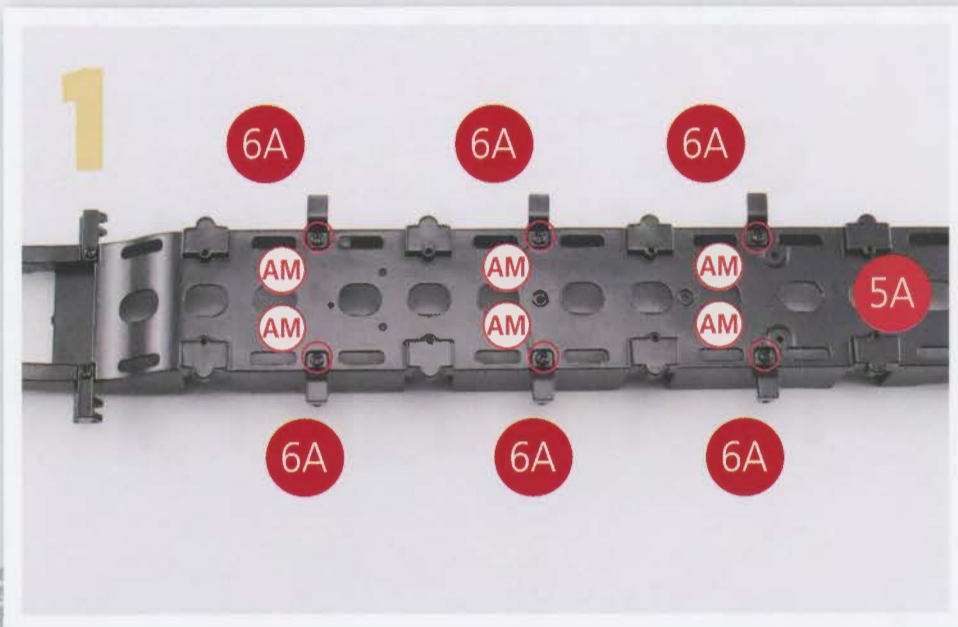

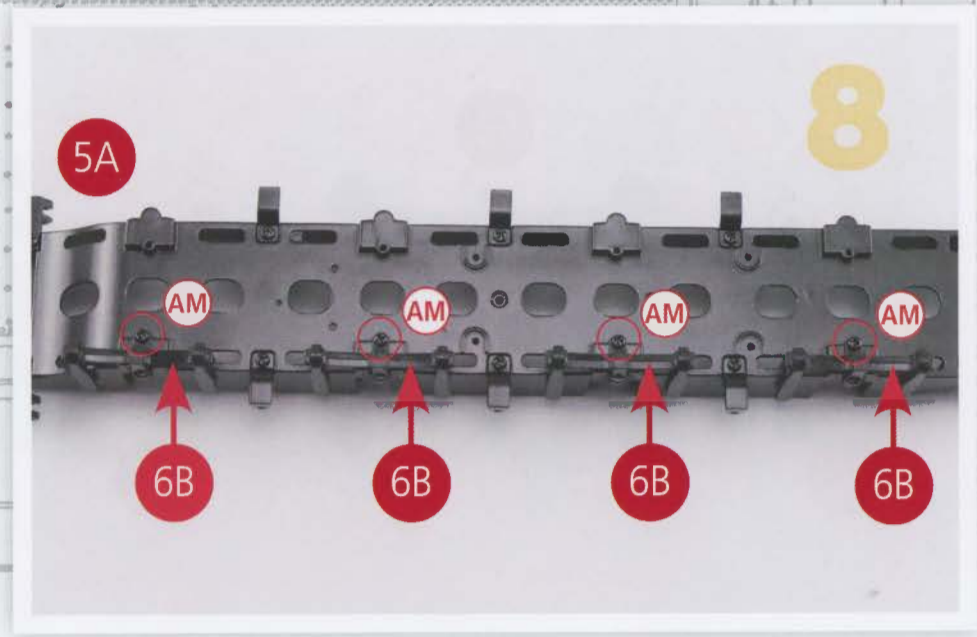
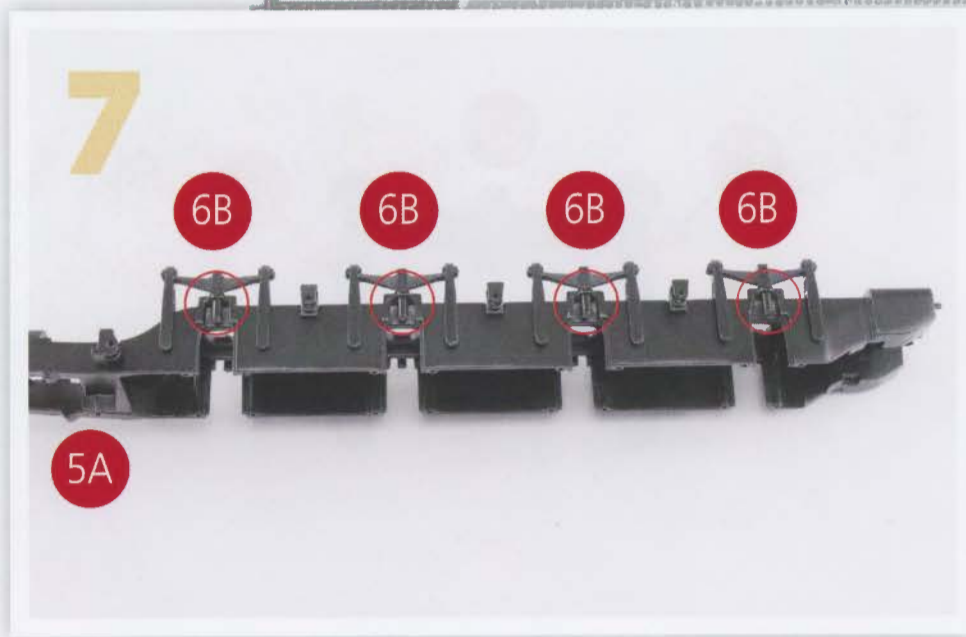
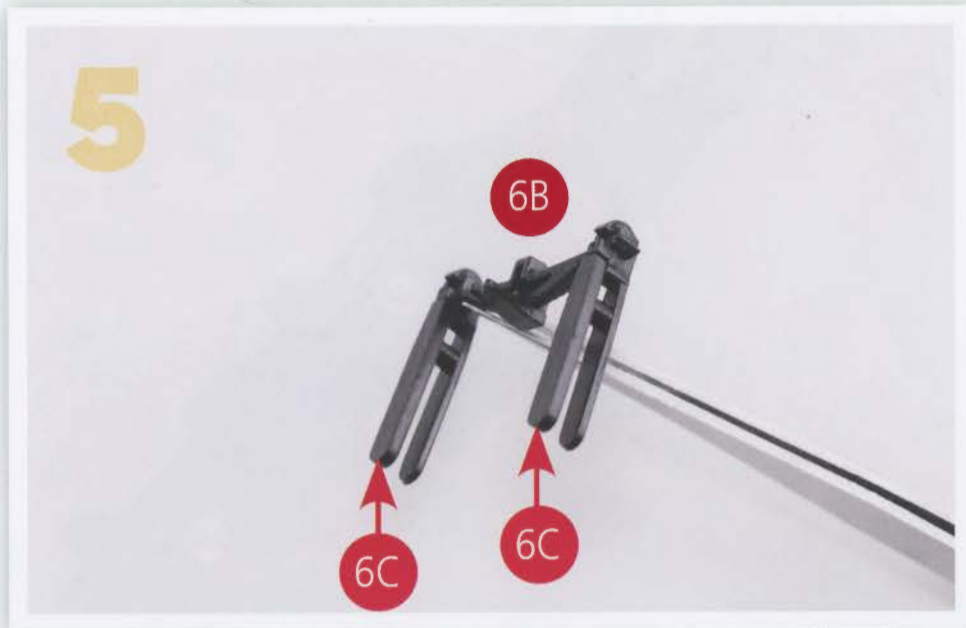

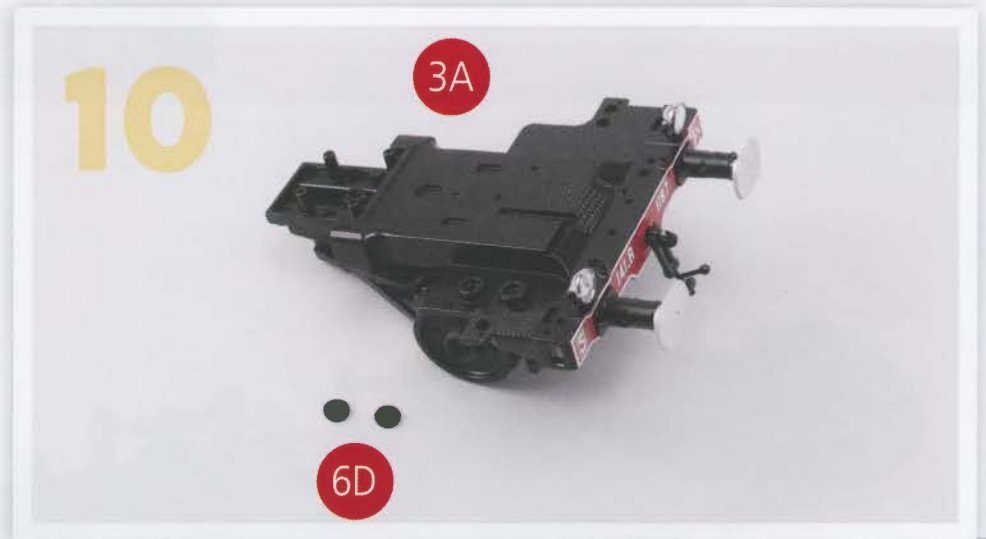
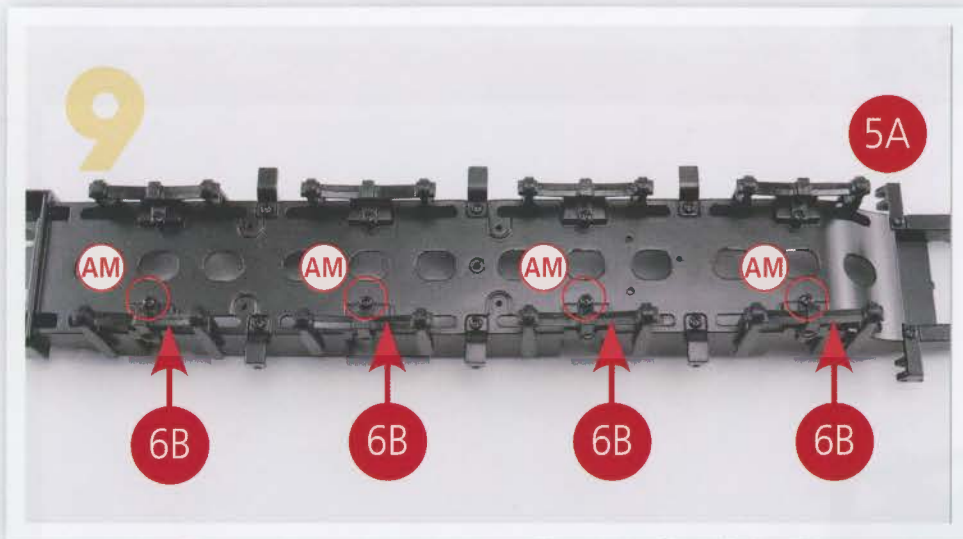

VUE FINALE





GUIDE DE MONTAGE

Montage du 1^{er} essieu moteur : boîtes, corps d'essieu, et ressorts

IXOBOX N°2

Les pièces du kit numéro 7

- 7A** Roue mortice (x2)
 - 7B** Corps d'essieu
 - 7C** Fermeture du logement de la boîte d'essieu (x2)
 - 7D** Face extérieure de la boîte d'essieu (x2)
 - 7E** Face intérieure de la boîte d'essieu (x2)
 - 7F** Ressort de suspension (x2)
 - 7G** Barre de protection de la suspension
 - AM** M1,7 x 4 (6 + 1)
 - KP** M1,4 x 4 (2 + 1)
- Tournevis**

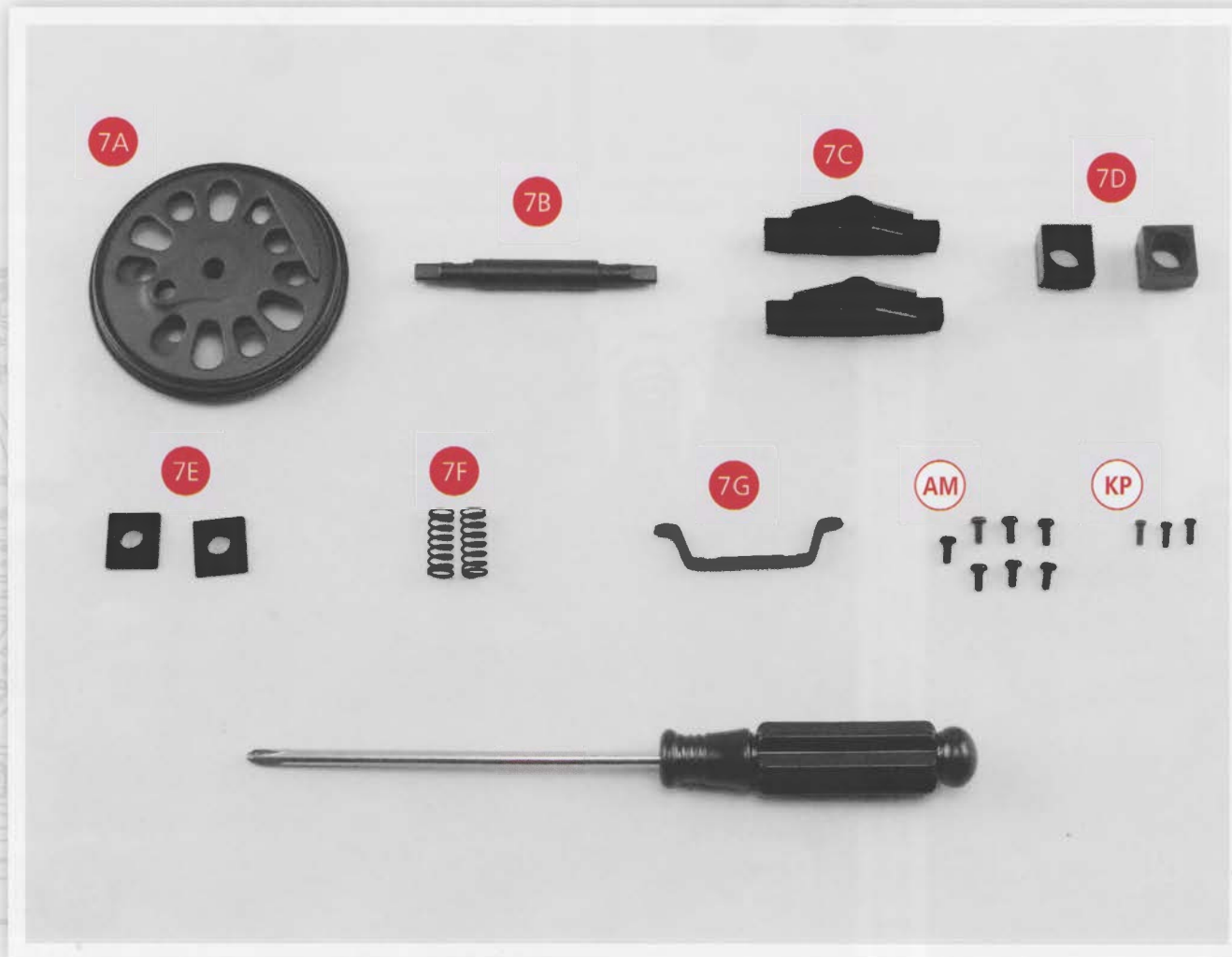

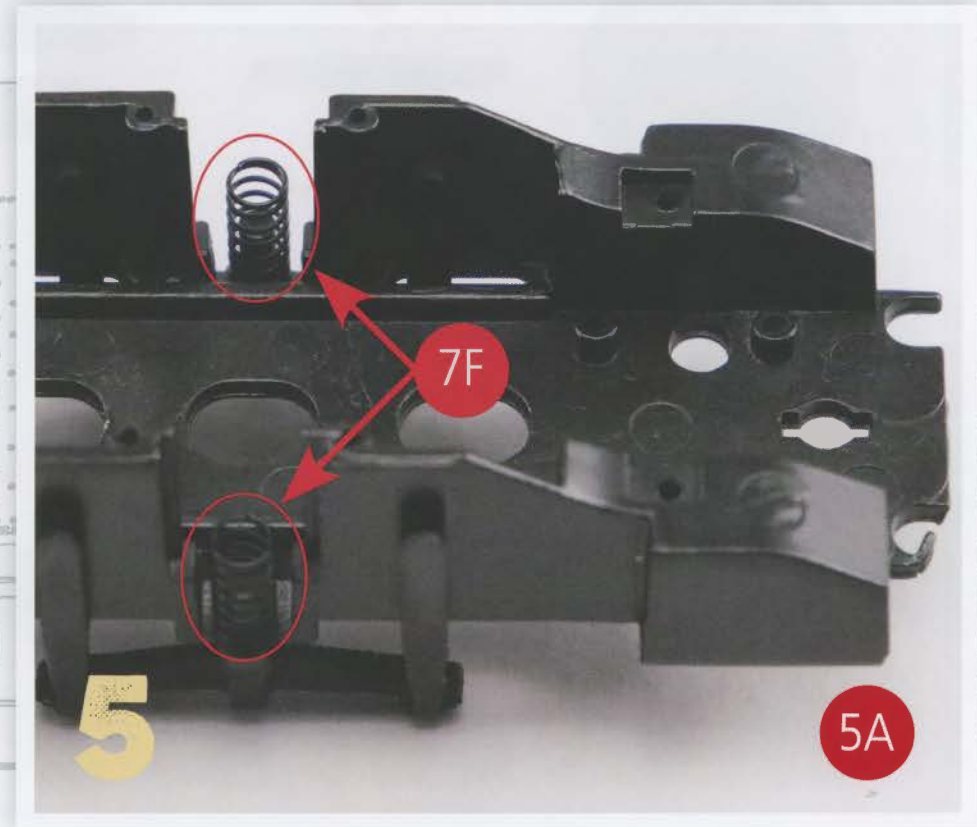
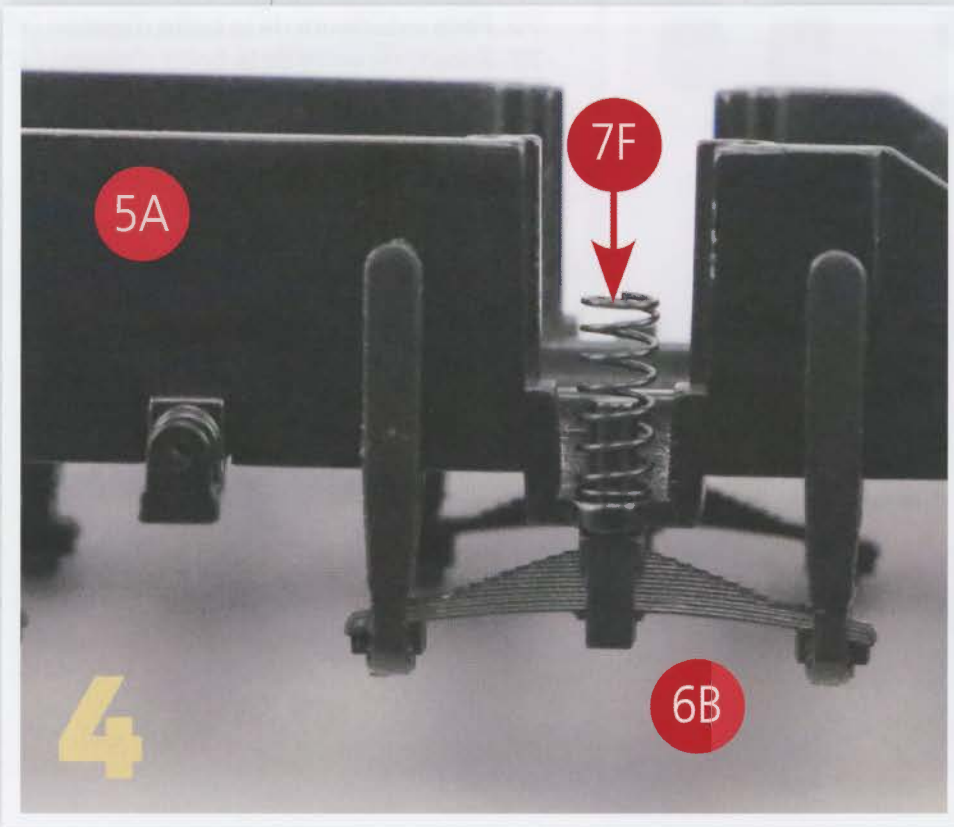
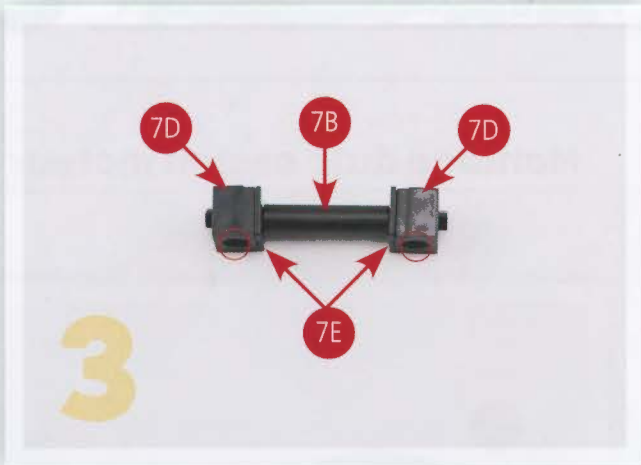
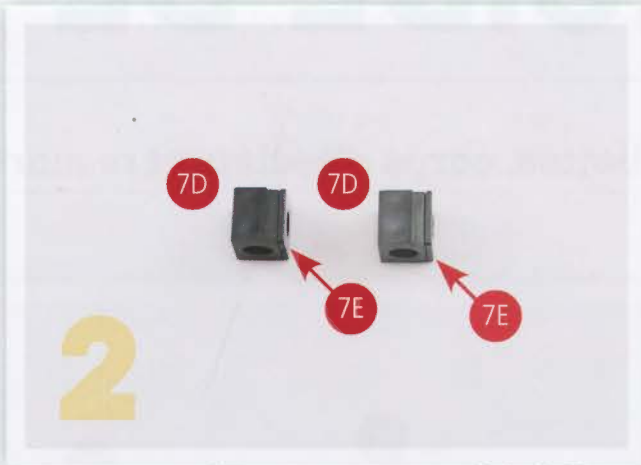
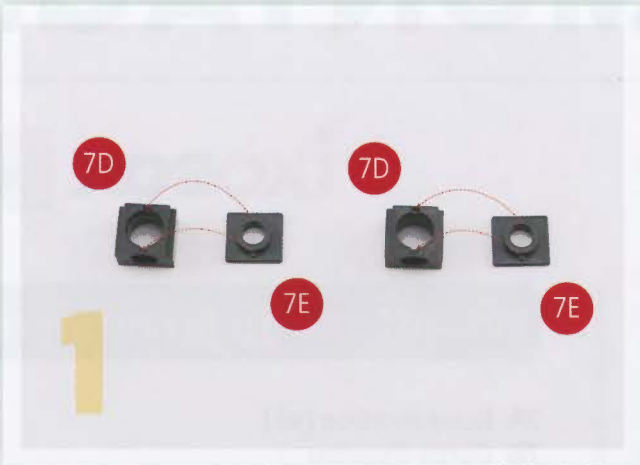

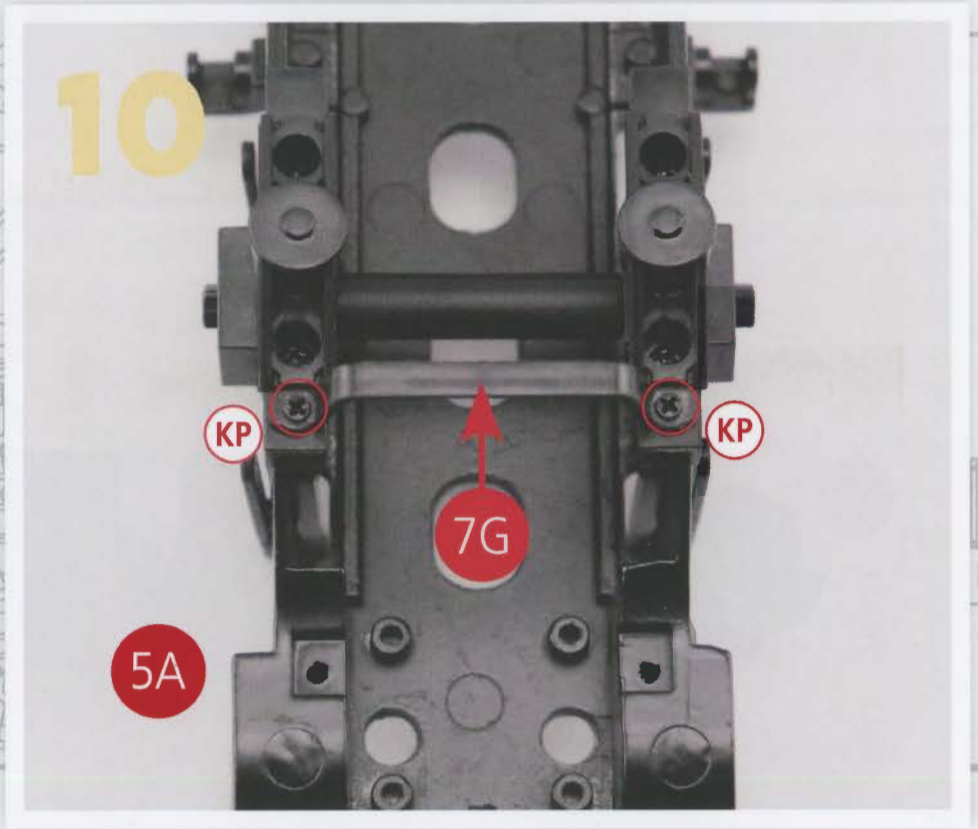
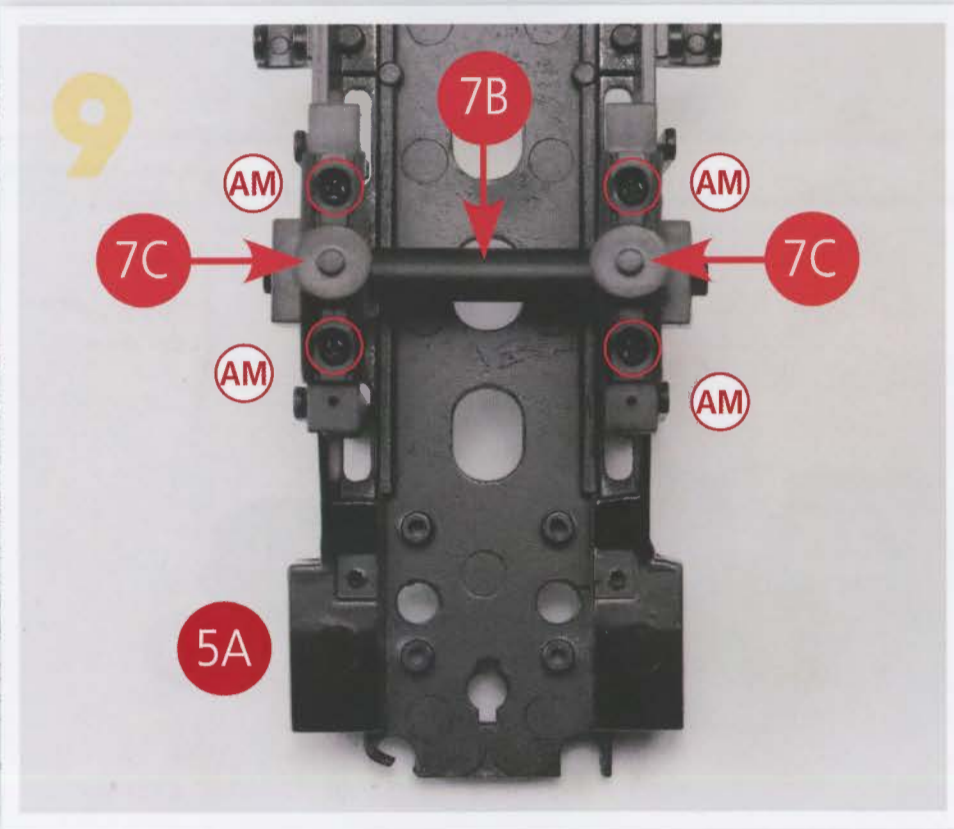
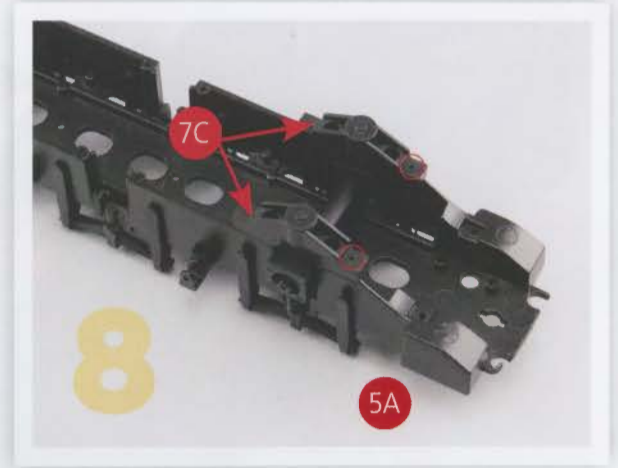
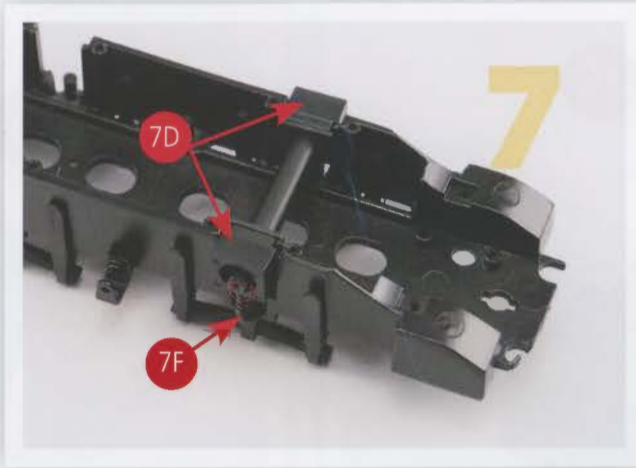

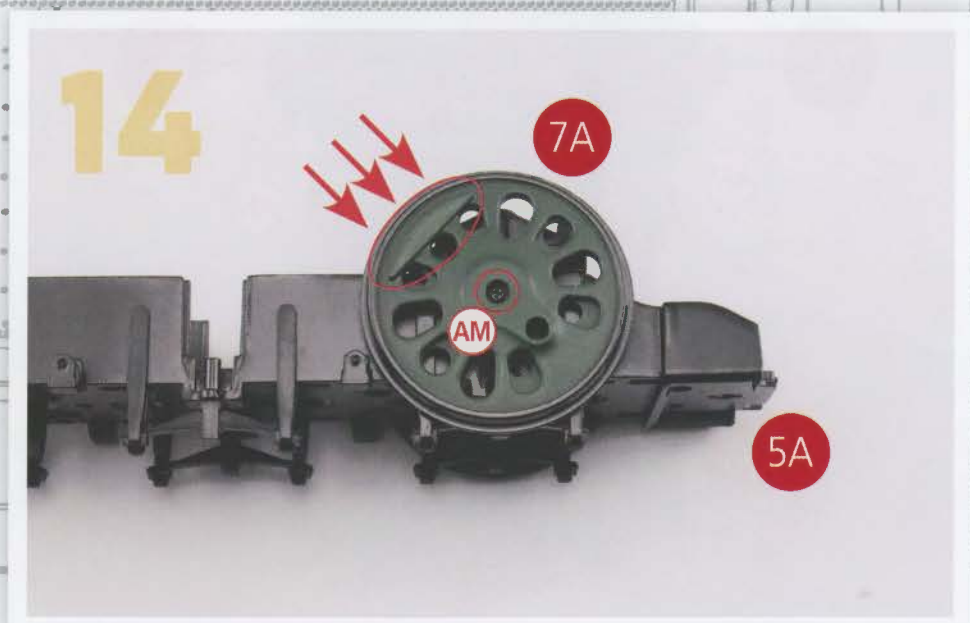
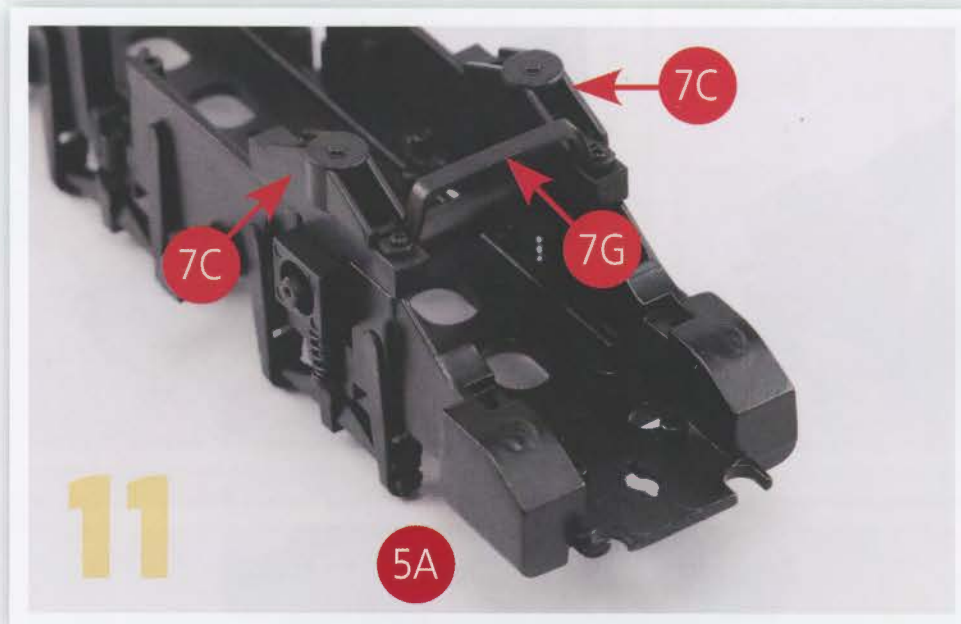

VUE FINALE

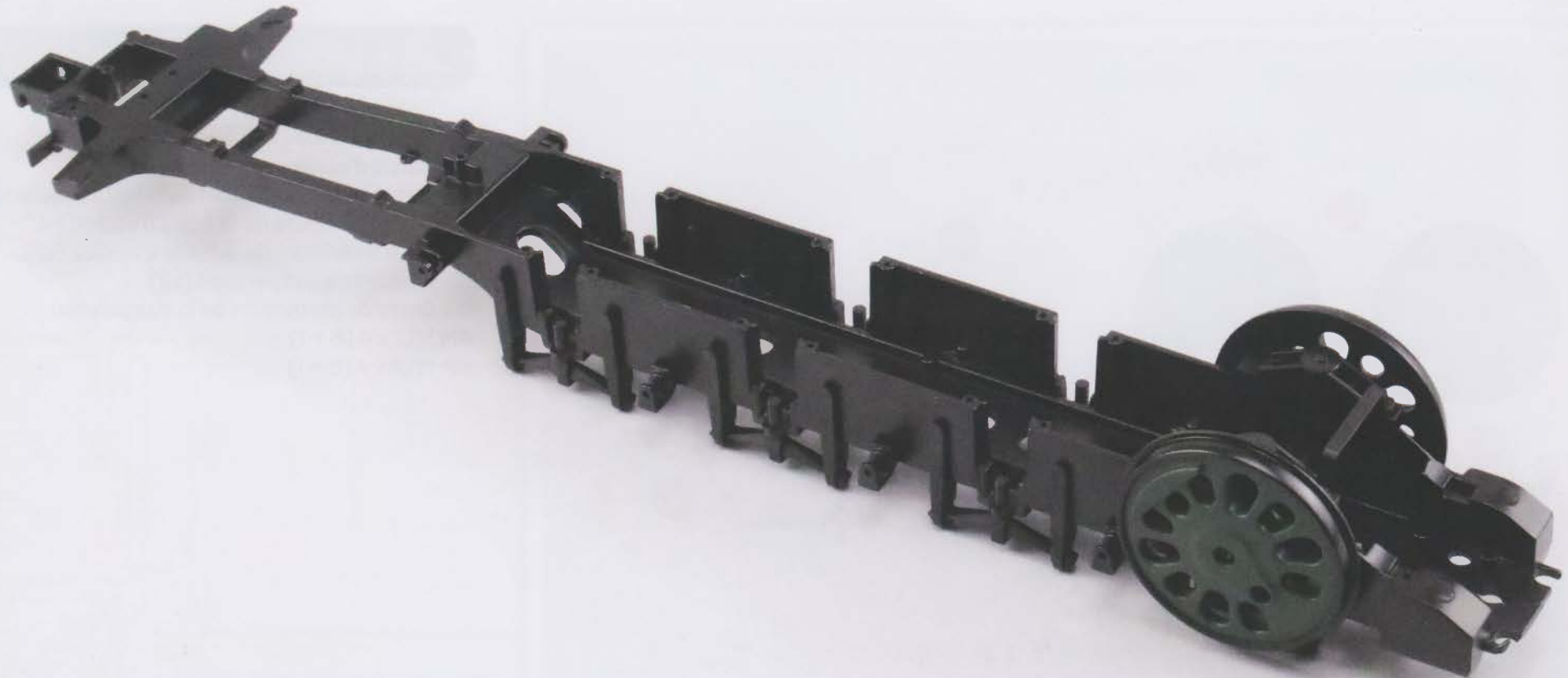



GUIDE DE MONTAGE

Montage du 2^e essieu moteur : boîtes, corps d'essieu, et ressorts

IXOBOX N°2

Les pièces du kit numéro 8

- 8A** Roue motrice (x2)
- 8B** Corps d'essieu
- 8C** Fermeture du logement de la boîte d'essieu (x2)
- 8D** Face extérieure de la boîte d'essieu (x2)
- 8E** Face intérieure de la boîte d'essieu (x2)
- 8F** Ressort de suspension (x2)
- 8G** Barre de protection de la suspension
- AM** M1,7 x 4 (6 + 1)
- KP** M1,4 x 4 (2 + 1)

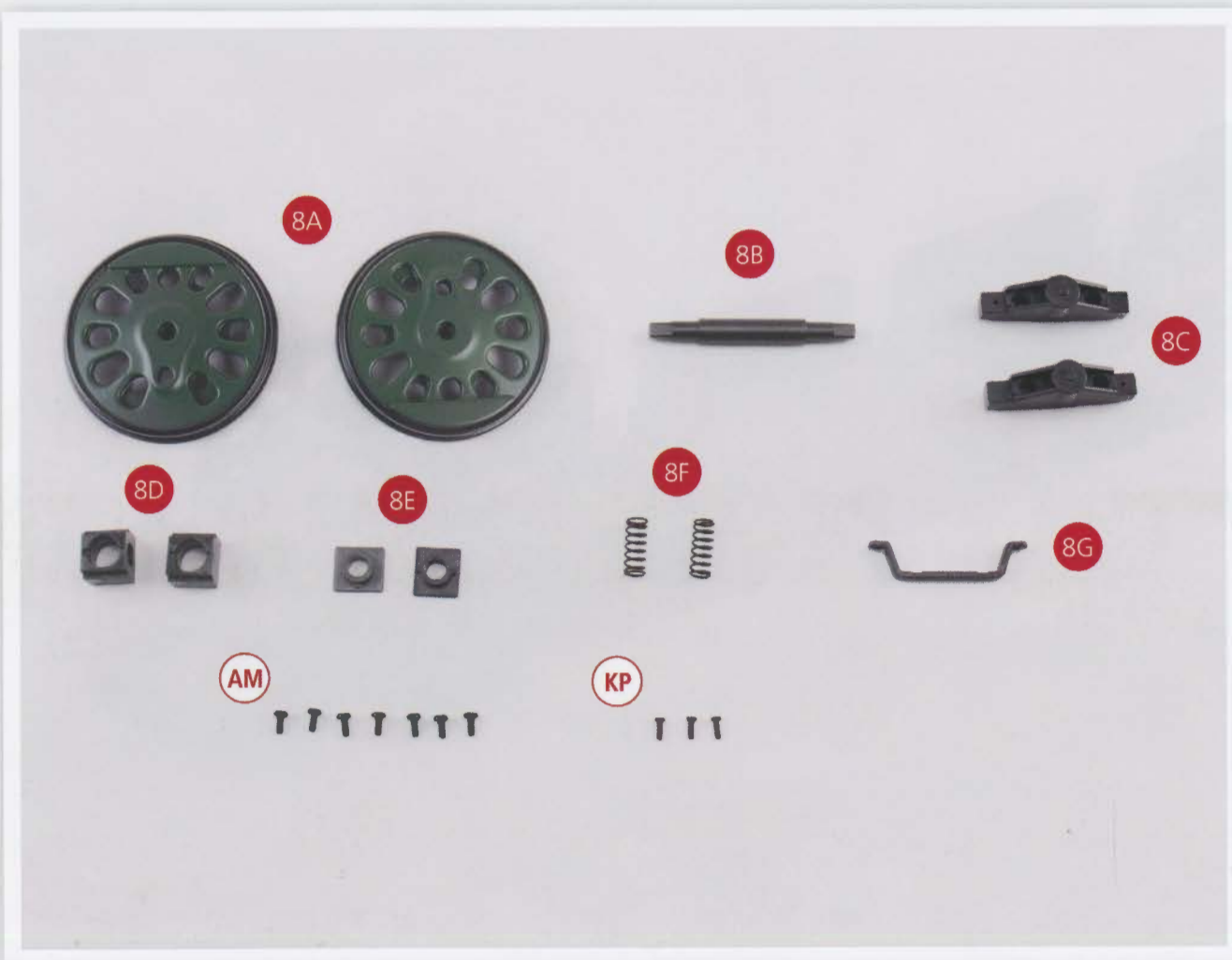

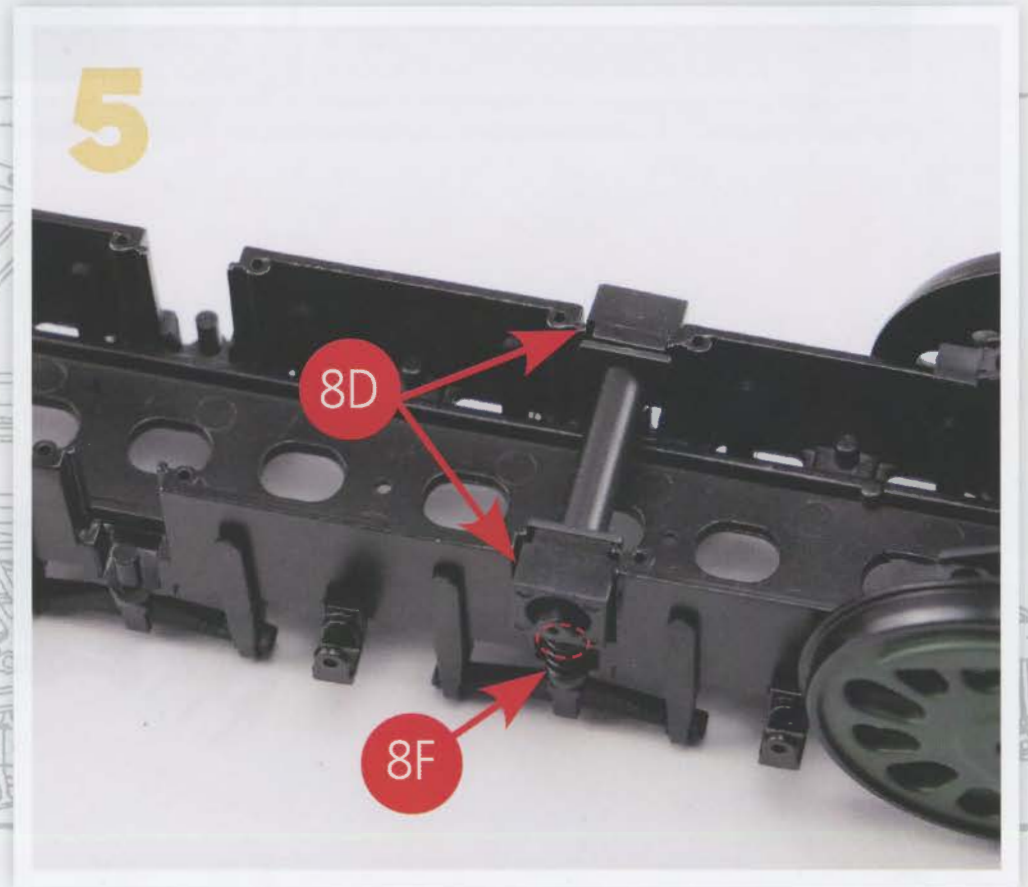
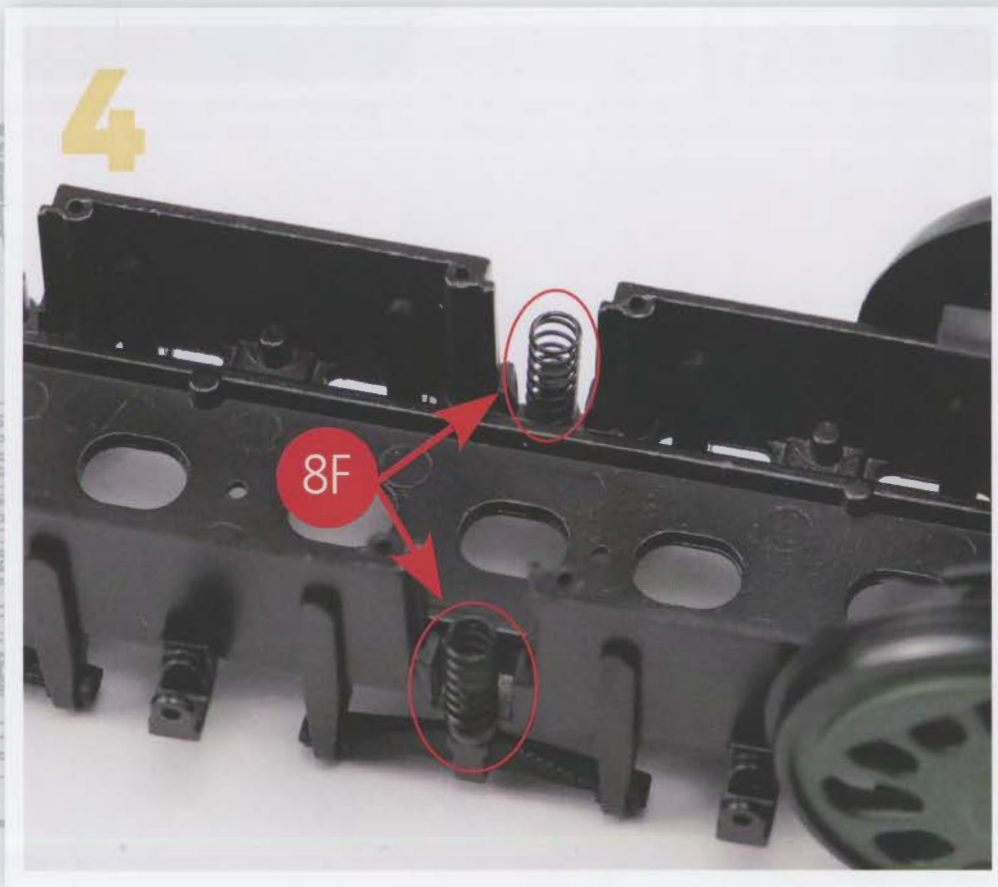
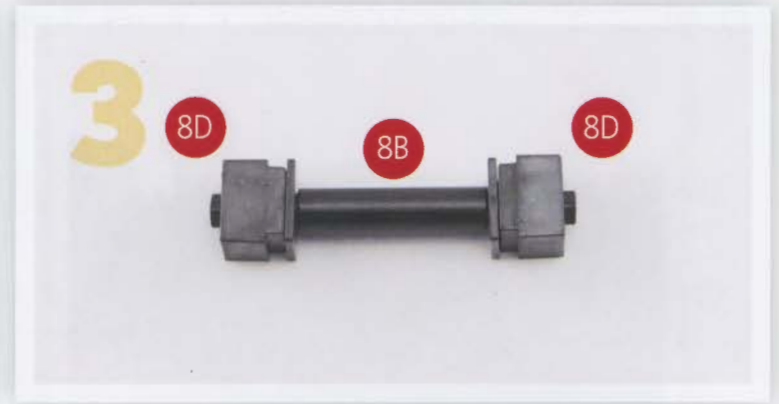
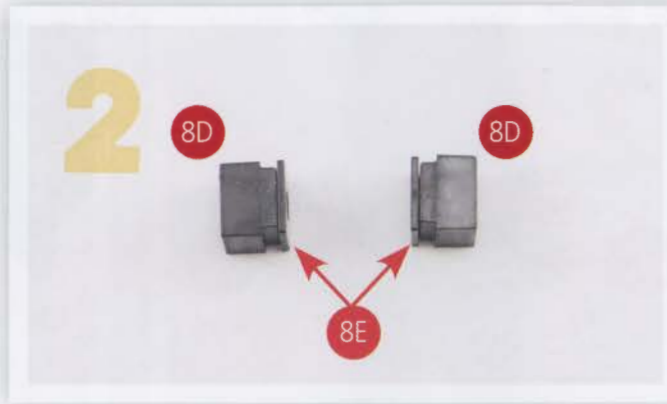
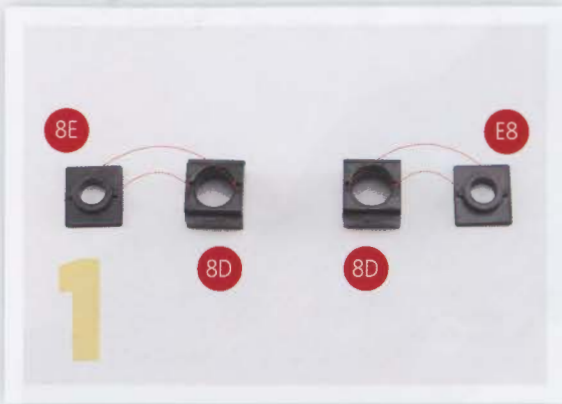

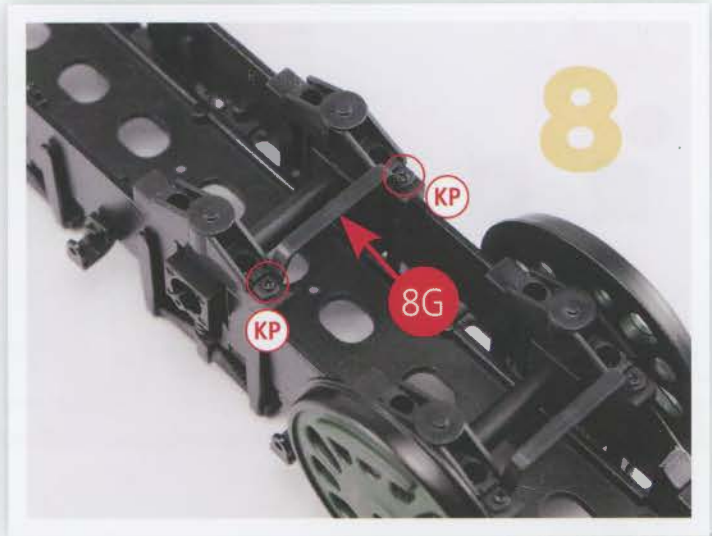
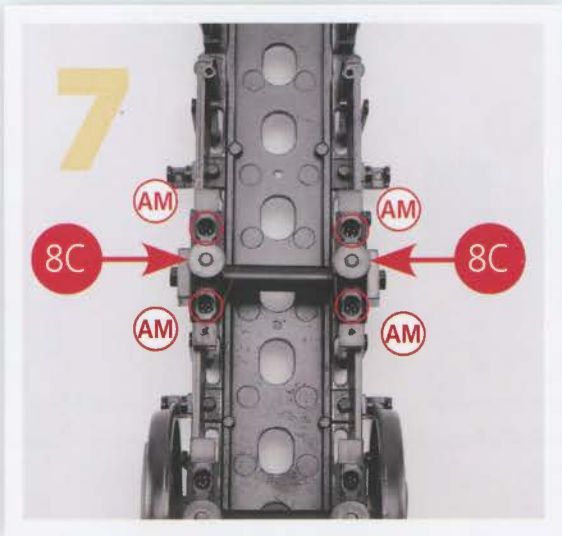
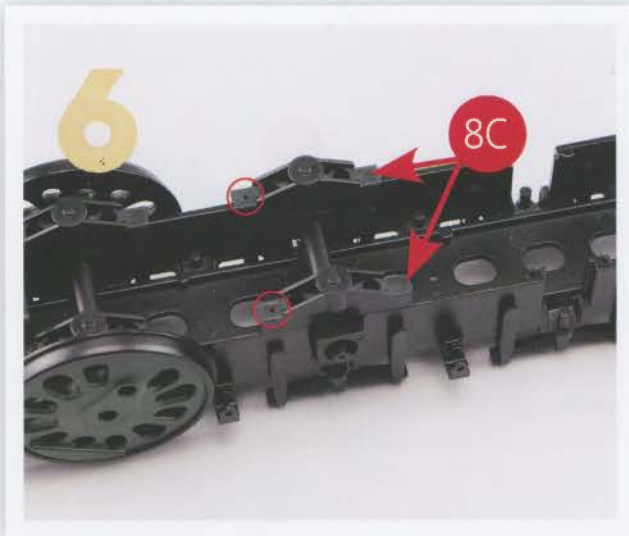

VUE FINALE

